

MLK HTJ

AIR-WATER HEAT PUMPS FOR OUTDOOR INSTALLATION



Options

Operating mode

R - Heating and cooling
(reversible on refrigerant side)

Heat recovery

Base version
Desuperheater version

Acoustic setting up

B - Base setting up
S - Low noise setting up

Plant side flow rate management

None
Standard pump
Modulating pump
High head pump

Compressor starter

Standard
Soft starter

Accessories

Vibration dampers
Remote interface

DATI TECNICI	18	24	30	38	49	
Efficiency class - EU reg 811/2013 <i>average climate - medium temperature application</i>	A++	A++	A++	A++	A++	-
Power supply	400V - 3N - 50Hz					-
Refrigerant	R410A					-
Type of compressors	high temperature scroll with vapour injection					-
N° of compressors / N° of refrigerant circuits	2 / 1					-
Type of plant side heat exchangers	stainless steel brazed plates					-
Type of source side heat exchangers	finned coil copper - hydrophilic aluminum					-
Type of fans	axial EC					-
N° of fans	1	1	1	2	2	-
Hydraulic fittings	1"1/2 M	1"1/2 M	1"1/2 M	1"1/2 M	1"1/2 M	-
Weight *	311	314	374	446	449	kg
Maximum power input *	9,0	11,6	14,2	20,4	23,6	kW

* base unit without options and accessories

OPERATING RANGE	HEATING		COOLING		
	min	max	min	max	
Water outlet temperature	15	65 *	6	25	°C
Outside air inlet temperature	-22	42	5	50	°C

* The maximum water outlet temperature can be increased up to 70°C keeping a ΔT of 10°C between inlet and outlet

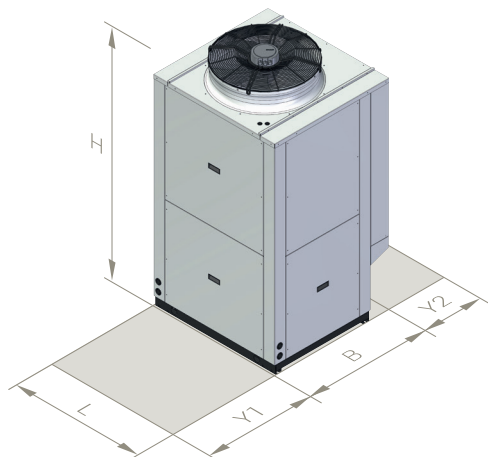

	18	24	30	38	49	
L	980	980	1330	1730	1730	mm
B	930	930	930	930	930	mm
H	1830	1830	1830	1830	1830	mm
Y1	1000	1000	1000	1000	1000	mm
Y2	500	500	500	500	500	mm

HEATING		A	W	18	24	30	38	49	
A7W35	Heating capacity	7	35	17,5	23,6	30,3	39,8	50,0	kW
	Power input			3,78	5,13	6,48	8,54	10,8	kW
	COP			4,63	4,60	4,68	4,66	4,63	-
	Plant side water flow rate			3010	4064	5221	6863	8623	l/h
	Plant side pressure drops			20	22	22	25	30	kPa
A7W45	Heating capacity	7	45	17,7	23,9	30,7	40,3	50,6	kW
	Power input			4,82	6,54	8,27	10,90	13,8	kW
	COP			3,67	3,65	3,71	3,70	3,67	-
	Plant side water flow rate			3056	4127	5302	6969	8755	l/h
	Plant side pressure drops			21	22	22	25	31	kPa
A7W55	Heating capacity	7	55	18,0	24,2	31,1	40,9	51,4	kW
	Power input			5,89	7,99	10,10	13,3	16,9	kW
	COP			3,06	3,03	3,08	3,08	3,04	-
	Plant side water flow rate			1952	2635	3385	4450	5591	l/h
	Plant side pressure drops			9	10	9	11	13	kPa
A7W65	Heating capacity	7	65	18,4	24,8	31,8	41,9	52,6	kW
	Power input			7,34	9,96	12,60	16,6	21,0	kW
	COP			2,51	2,49	2,52	2,52	2,50	-
	Plant side water flow rate			1604	2166	2782	3657	4594	l/h
	Plant side pressure drops			6	7	7	7	9	kPa
A2W35	Heating capacity	2	35	14,7	19,9	25,5	33,6	42,2	kW
	Power input			3,78	5,12	6,48	8,53	10,8	kW
	COP			3,89	3,89	3,94	3,94	3,91	-
	Plant side water flow rate			2539	3429	4405	5790	7275	l/h
	Plant side pressure drops			15	16	16	18	22	kPa
A2W45	Heating capacity	2	45	15,0	20,2	26,0	34,1	42,9	kW
	Power input			4,82	6,53	8,26	10,90	13,8	kW
	COP			3,11	3,09	3,15	3,13	3,11	-
	Plant side water flow rate			2589	3496	4491	5904	7417	l/h
	Plant side pressure drops			15	16	16	18	23	kPa
A2W55	Heating capacity	2	55	15,3	20,6	26,5	34,8	43,7	kW
	Power input			5,90	8,00	10,10	13,3	16,9	kW
	COP			2,59	2,58	2,62	2,62	2,59	-
	Plant side water flow rate			1661	2243	2881	3787	4758	l/h
	Plant side pressure drops			7	7	7	8	10	kPa
A2W65	Heating capacity	2	65	15,7	21,2	27,2	35,8	45,0	kW
	Power input			7,35	9,97	12,60	16,6	21,1	kW
	COP			2,14	2,13	2,16	2,16	2,13	-
	Plant side water flow rate			1372	1853	2381	3130	3932	l/h
	Plant side pressure drops			4	5	5	6	7	kPa

COOLING		A	W	18	24	30	38	49	
A35W7	Cooling capacity	35	7	14,7	19,8	25,5	33,6	42,1	kW
	Power input			4,57	6,20	7,83	10,30	13,1	kW
	EER			3,22	3,19	3,26	3,26	3,21	-
	Plant side water flow rate			2540	3415	4393	5783	7259	l/h
	Plant side pressure drops			15	16	16	18	22	kPa
A35W18	Cooling capacity	35	18	19,4	26,2	33,7	44,3	55,6	kW
	Power input			4,96	6,72	8,49	11,2	14,2	kW
	EER			3,91	3,90	3,97	3,96	3,92	-
	Plant side water flow rate			3374	4536	5836	7682	9643	l/h
	Plant side pressure drops			25	27	27	31	38	kPa

ACOUSTIC PERFORMANCES		A	W	18	24	30	38	49	
Base	Sound power level	7	35	72	73	75	77	79	dB(A)
	Sound pressure level - 1 m			56	57	59	60	62	dB(A)
	Sound pressure level - 5 m			46	47	49	50	52	dB(A)
	Sound pressure level - 10 m			41	42	44	45	47	dB(A)
Low noise	Sound power level	7	35	70	71	72	74	76	dB(A)
	Sound pressure level - 1 m			54	55	56	57	59	dB(A)
	Sound pressure level - 5 m			44	45	46	47	50	dB(A)
	Sound pressure level - 10 m			39	40	41	42	45	dB(A)

Data declared according to EN 14511. Acoustic performances declared according to EN 12102. The data are related to reversible units (R) without options or accessories.

A7W35	= source:	air in 7°C db 6°C wb	plant:	water in 30°C out 35°C	A2W35	= source:	air in 2°C db 1°C wb	plant:	water in 30°C out 35°C
A7W45	= source:	air in 7°C db 6°C wb	plant:	water in 40°C out 45°C	A2W45	= source:	air in 2°C db 1°C wb	plant:	water in 40°C out 45°C
A7W55	= source:	air in 7°C db 6°C wb	plant:	water in 47°C out 55°C	A2W55	= source:	air in 2°C db 1°C wb	plant:	water in 47°C out 55°C
A7W65	= source:	air in 7°C db 6°C wb	plant:	water in 55°C out 65°C	A2W65	= source:	air in 2°C db 1°C wb	plant:	water in 55°C out 65°C
A35W7	= source:	air in 35°C db	plant:	water in 12°C out 7°C					
A35W18	= source:	air in 35°C db	plant:	water in 23°C out 18°C					